

Water Fun & Safety

By Barb Stephens

Water Safety

For each statement, circle the correct answer, DO or DON'T.

DO DON'T 1. Show off in the water.

DO DON'T 2. Dive into strange or shallow waters

DO DON'T 3. Go in swimming right after eating.

DO DON'T 4. Have your family physician tell you of any problems found in your fitness checkup

Swimming & Rescue

Using words from the list below, fill in the correct answer for each description.

Surface Dive
Sidestroke

Crawl Stroke
Reach

Backstroke
Buddy System

Go
Throw

1. Swimming with a buddy is good common sense because you can help each other if one gets in trouble or help each other to improve swimming skills.
2. This stroke begins with floating on your back.
3. This stroke is done on either your left side or your right side.
4. In this stroke your head changes from facing down to facing to the side so you can take a breath of air.
5. This skill involves floating face down, then bending sharply at the waist and aiming toward the bottom.
6. Rescue method where you extend something for the victim to grab onto.
7. This rescue method involves providing a floating device to the victim.
8. This is the last rescue choice where you must get to the victim, preferably in a boat or other form of support

Boating Safety

Circle the correct answer(s) for each statement.

1. In a rowboat (1 OR 2 OR 3) people per seat is a safe rule.
2. (Children OR Scouts OR Adults) should wear a life jacket in a boat 20 feet or shorter.
3. If your boat tips over (swim to shore OR hang onto the boat).
4. Always keep a lookout for (other boats OR swimmers OR sharks).

Fun With Colors

By Barb Stephens

COLOR BASICS

PRIMARY COLORS

Black
Blue
Green
Grey
Orange
Purple
Red
White
Yellow

SECONDARY COLORS

NEUTRAL COLORS include _____, _____, _____.

THE COLOR WHEEL

Secondary colors are those made by mixing equal amounts of two primary colors. Fill in the boxes with the appropriate *secondary colors*.

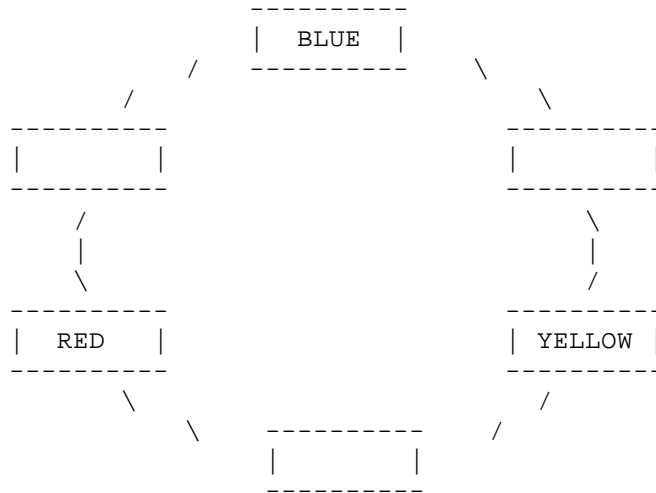

COMPLEMENTARY COLORS

Complementary colors are those that are opposite each other on the color wheel. Write down 3 pairs of *complementary colors*.

Can two primary colors be complementary to each other? _____

Can two secondary colors be complementary to each other? _____

Do you see a pattern? _____

Being Physically Healthy

By Barb Stephens

Good Health Habits

Circle the correct answer(s).

1. Bathe/shower (every/day OR 1/week) and especially after exercise.
2. Wash your hair (1/month OR 2+ times/week).
3. Wash hands (before eating OR after using the restroom) and when they're dirty.
4. Eat right - (3 OR 4 OR 6) regular meals each day at regular times!
5. Eat (just some OR a variety of) food from each of the 4 food groups.
6. The average 10 year old should get (6 OR 9 OR 12) hours of sleep each night.

Clean & Strong

Circle T for True or F for False.

- T F 1. Our bodies "repair" themselves while we sleep.
- T F 2. Clean clothes aren't necessary after a bath or shower - they are just in the morning.
- T F 3. Use proper lighting for all activities including reading, TV viewing, and playing.
- T F 4. Fitness is never just physical - it involves both the mind and body together.
- T F 5. Stand tall, and walk tall with shoulders back and stomach in.
- T F 6. It's OK to share drinking cups, washcloths and towels.
- T F 7. Different foods provide different nutrients, and no one food can sustain us.
- T F 8. Rushing meals or skipping meals can be harmful to your body.

Basic Food Groups

Match each food to the appropriate food group.

DAIRY

PROTEIN

GRAINS

VEG & FRUIT

banana
porkchop
cheese
melon
potatoes

egg
apple
hotdogs
nuts
milk

cereal
butter
corn
crackers
oatmeal

yogurt
pasta
bread
ice cream
steak

Exercise, Exercise, Exercise

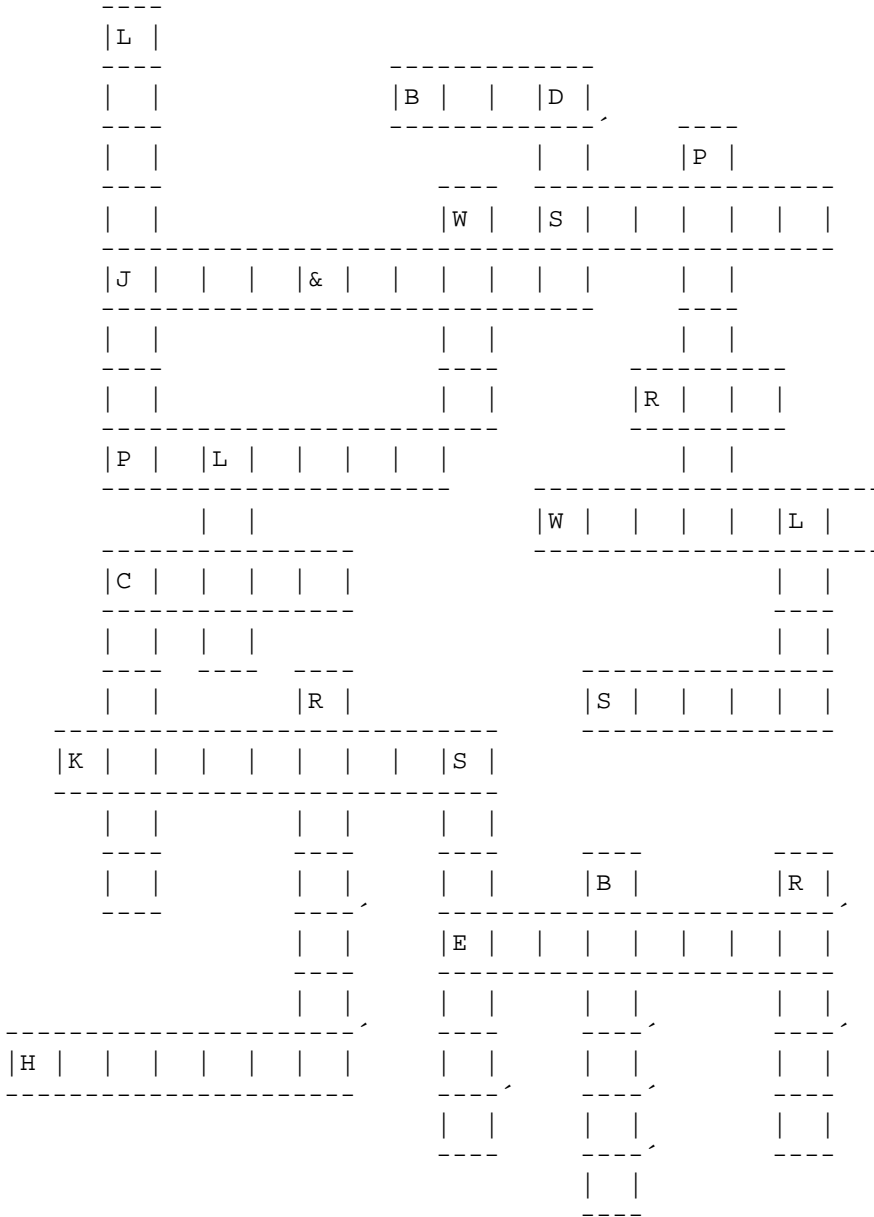

Place the following words into the crossword spaces above. The first letter of each word is already filled in for you!

Bend
Dash
Kneebends
Pullups
Run
Walk

Bridge
Exercise
Leap
Pushups
Situps
Wrestle

Crawl
Hurdles
Lift
Records
Squat

Crunch
Jump&Reach
Longjump
Relay
Stretch

Presidents Name Search

By Barb Stephens

E C R E I P T R N A G A E R B C E J K A
 W T A F T T X I R X W H N O F O R D D O
 N V X C Y N J E F F E R S O N W X A R Y
 O Q P L D F I L L M O R E S N I M P B E
 T H E C E A M P T U J L S E I S X O L L
 N R L I N C O L N F D B R V O L B O B N
 I W R R N P Z L A T U Z E E W C J H N I
 L V P U E K O O R C Y N T L A O W A S K
 C H A Q K H N L G I O V R T M T A Y E C
 B U C H A N A N K S A D A W R S S E I M
 R G N I D R A H K N H R C O O D H S S A
 N W I X F F N C B B O O I L L O I E E D
 O T I G E R A U E E O D E F Y Z N E N I
 S B J S C J R W R L V W L Y A D G O H S
 I R O C A E E E I O E E E E T L T R O O
 R U H O N S I D U L R N R B I R O N W N
 R H N U M W G C T H S U B A E F N O E N
 A T S T L E A W I L S O N D H L R M R A
 H R O S P V D N A L E V E L C S O A U N
 E A N A M U R T L H B F I B E A R S G F

Washington
 Monroe
 Harrison
 Fillmore
 Johnson
 Arthur
 McKinley
 Harding
 Truman
 Nixon
 Bush

Adams
 (Adams)
 Tyler
 Pierce
 Grant
 Cleveland
 Roosevelt
 Coolidge
 Eisenhower
 Ford
 Clinton

Jefferson
 Jackson
 Polk
 Buchanan
 Hayes
 (Harrison)
 Taft
 Hoover
 Kennedy
 Carter

Madison
 VanBuren
 Taylor
 Lincoln
 Garfield
 (Cleveland)
 Wilson
 (Roosevelt)
 (Johnson)
 Reagan

CUBS
 WOLF

SCOUTS
 BEAR

TIGER
 WEBELOS

BOBCAT

A Good Citizen Knows ...

A

1. If you meet the President, you call him:
 - a. your Highness
 - b. your Excellency
 - c. Mr. President
2. The President and his family live in:
 - a. Blair House
 - b. the White House
 - c. the suburbs
3. The first President to live in the White House was:
 - a. John Adams
 - b. George Washington
 - c. Thomas Jefferson
4. We celebrate birthdays of two Presidents in February; they are:
 - a. Washington and Lincoln
 - b. Jefferson and Adams
 - c. T. Roosevelt and F.D. Roosevelt
5. During the War of 1812, when Madison was President, this famous song was written:
 - a. the Battle Hymn of the Republic
 - b. God Bless America
 - c. The Star Spangled Banner
6. Twenty-seven Presidents have studied:
 - a. flying
 - b. law
 - c. astronomy
7. The two big political parties today are:
 - a. Republicans and Democrats
 - b. Federalists and Whigs
 - c. Conservatives and Liberals
8. The U S National Anthem was written by:
 - a. George Washington
 - b. Francis Scott Key
 - c. Benjamin Franklin
 - d.
9. The law says Presidential elections must be held on:
 - a. the first Monday in October
 - b. Halloween
 - c. the first Tuesday in November

B

1. We hold Presidential elections every:
 - a. two years
 - b. four years
 - c. six years
2. The United States is made up of:
 - a. 13 states
 - b. 37 states
 - c. 50 states
3. The parties pick their Presidential candidates in:
 - a. Presidential primaries
 - b. national nominating conventions
 - c. by secret vote
4. If a president dies in office, the next president is:
 - a. the Vice President
 - b. elected by the people
 - c. the oldest Senator
5. If you want to run for President you should:
 - a. go jogging
 - b. take a nap
 - c. make speeches
6. The only man to be elected President four times was:
 - a. Abraham Lincoln
 - b. Franklin Delano Roosevelt
 - c. Ulysses S. Grant
7. The President's wife is called:
 - a. the First Lady
 - b. the Queen
 - c. Mrs. President
8. The U S flag's stripes are colored:
 - a. 6 red and 7 white
 - b. 7 red and 6 white
 - c. 6 red and 6 white
9. When properly folded, the U S flag should be shaped like:
 - a. a circle
 - b. a square
 - c. a triangle

Cub Scout Alphabet Soup

By Barb Stephens

Using the letter of the alphabet displayed, fill in the answer for each clue.

The first one has been done for you.

The "Jungle Book" name of an important Cub Scout Leader is **Akela**.

When they are old enough, Cub Scouts can join a troop of **B**_____.

The title of the leader of the Pack is **C**_____.

The title of the Cub Scout who is the number one den helper is the **D**_____.

One Cub Scout elective activity which could include wiring a door bell is **E**_____.

Every Cub Scout shows respect to this patriotic item that is used in opening ceremonies, the **F**_____.

The Webelos activity badge that includes the study of rocks, minerals, mountains and earthquakes is **G**_____.

A physical journey that Scouts big and small enjoy in the outdoors is a **H**_____.

This substance is found in instruments we write with: **I**_____.

Kids like to see how far or how high they can do this physical action: **J**_____.

One way to move the ball in football or soccer is to **K**_____ it.

This is the noise we make when something is funny or we are happy: **L**_____.

This is made by voices or by instruments: **M**_____.

A familiar information source that contains many articles and is often recycled is a **N**_____.

People from many nations around the world take part in the **O**_____ events every four years.

These play characters are fun to make and are used in some skits: **P**_____.

The Cubmaster expects **Q**_____ when he give the Cub Scout sign.

During races or relays we move our legs quickly and this is called **R**_____.

The act of making musical sounds with words is another word for **S**_____.

When the Cub Scout sign is given, we must stop **T**_____.

A shirt, neckerchief and slide are part of the Cub Scout **U**_____.

During the summer, we often take time for a family **V**_____.

When a Cub Scout is 10 years old, and in the 4th or 5th grade, he can earn the Cub Scout rank of **W**_____.

The musical instrument, a **X**_____ sort of resembles a piano.

Today is **Y**_____ tomorrow.

A **Z**_____ is where lots of wild animals are kept for visitors to view.

Make It With Tools!

```

      -----
      | H |
      -----
      |   |
      -----
      | S | | | | | | | |
      -----
| P | | | | | | | |
-----
| | | | | | | | | L | | | T | | | | |
-----
| | | J | | S | | | F | | | | |
-----
| | | | | | | | | | | |
-----
| | | G | | | | | | | | L | | C | | N | |
-----
      | | | | | | | | | | | |
      -----
      | | | D | | | | | | | |
      -----
      | W | | | | | | | R | | | | | | |
      -----
      | | | | | | | | | | | |
      -----
| R | | | | | | | | | M |
-----
      | | | | | | | | | | | |
      -----
      | G | L | | | | | | |
      -----
      | | | | | | | | | | | |
      -----
      | | | | | | | | | | | |
      -----
      | | | | | | | | | | | |
      -----
      | P | | | | | | | S | | | |
      -----
      | | | | | | | | | | | |
      -----
      | B | | | | | | | |
      -----
      | | | | | | | |
      -----
  
```

Place the following words into the crossword spaces above. The first letter of each word is already filled in for you!

- | | | | |
|---------|-------------|-----------|----------|
| Blades | Bookrack | Clay | Dowel |
| Fire | Glass | Glue | Hammer |
| Jigsaw | Lacing | Leather | Level |
| Mailbox | Nails | Paint | Phillips |
| Plastic | Rope | Rubber | Screws |
| Shelf | Slab | Styrofoam | Tooling |
| Toolbox | Woodworking | | |

Tool Identification

By Barb Stephens

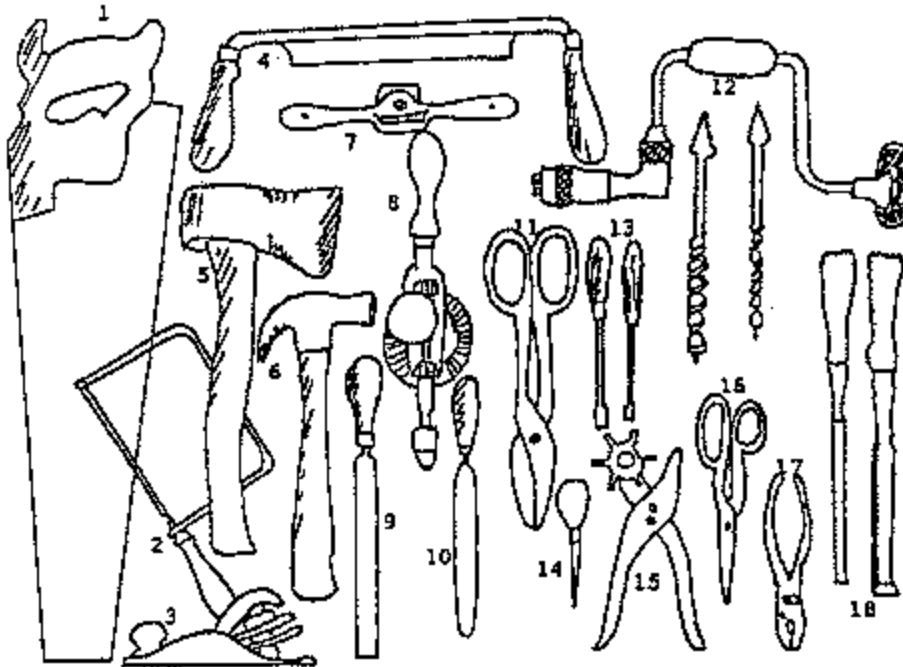

Pictured above are some basic tools Webelos Scouts may use when working with wood, leather, or tin. Place the appropriate number next to the named tool.

- | | | |
|--------------------|-----------------------|---------------------------|
| _____ Awl | _____ File | _____ Pliers (slip-joint) |
| _____ Ax (hand) | _____ Half-round File | _____ Saw |
| _____ Brace & Bits | _____ Hammer (claw) | _____ Screwdrivers |
| _____ Chisels | _____ Hand Drill | _____ Shears |
| _____ Coping Saw | _____ Leather Punch | _____ Spokeshave |
| _____ Drawknife | _____ Plane | _____ Tin Snips |

Careers In Engineering

By Barb Stephens

The Right "Man" for the Job!

Use a word from this list to fill in the correct answer.

Aeronautics Chemical Computer City Agricultural
Electrical Physical Industrial Mechanical Civil

10. An engineer who designs plants to make water safe to drink - _____.
11. An engineer who designs machines in a factory - _____.
12. An engineer who tests new processes and checks old ones in a chemical plant - _____.
13. An engineer who plans new circuits and directs workers in an electrical plant - _____.
14. An engineer who designs and tests new space techniques - _____.
15. An engineer who designs and tests new techniques for new equipment for industry - _____.
16. An engineer who designs and tests equipment for farmers and ranchers - _____.



PLANK BRIDGE

PIER BRIDGE



ARCH BRIDGE

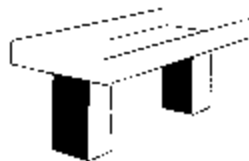

BEAM BRIDGE

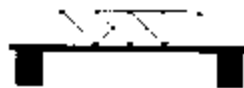

TRUSS BRIDGE

Bridges & Machines

Use a word from this list to fill in the correct answer.

Catapult Pulleys Beam Bridge Plank Bridge Truss Bridge
Arch Bridge Suspension Bridge Levers Block & Tackle Pier Bridge

1. A flat surface over two supports - _____.
2. A flat surface over three or more supports - _____.
3. A flat surface over an arched support - _____.
4. A flat surface with turned up edges - _____.
5. A bridge with sides made up of a series of triangles - _____.
6. A bridge that appears to hang from strong strung cables - _____.
7. A pulley(s) and a rope or cable - _____.
8. A slingshot or other device used to project something - _____.

Catapult Plans

By Barb Stephens

Basketball Catapult

Instructions

1. Base, backboard and hoop are made from a 1"x4" board.
2. Drill holes in base and backboard 3/8" diameter and 1/2" deep.
3. Cut a slot at a 15 degree angle in a cube block large enough for the handle of a plastic spoon.
4. Cut hole for the hoop first; then finish cutting the hoop piece.
(We used a slice of 2" diameter PVC pipe and screwed it into backboard.)
5. Glue the hoop to the backboard; then glue dowel rod into backboard and base.
6. Glue cube block to base and insert spoon into slot.
7. Cut string and attach one end to dowel rod at base and the other end to any 1" sized ball (ping pong balls work well).

Basketball Catapult

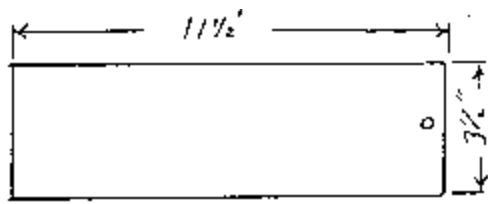

BASE

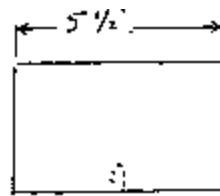

BACKBOARD

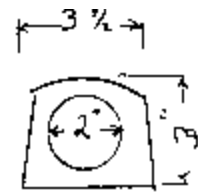

HOOP

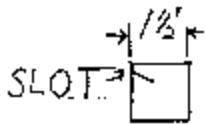

CUBE

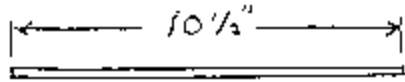

$\frac{3}{8}$ DOWEL

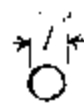

BALL

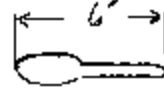

PLASTIC SPOON

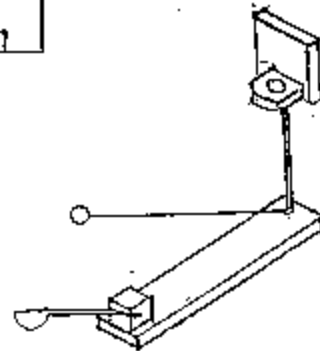
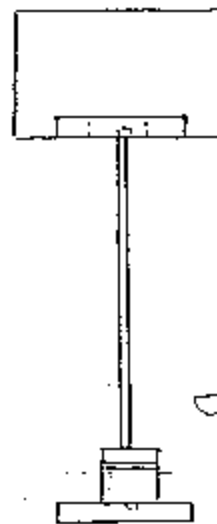
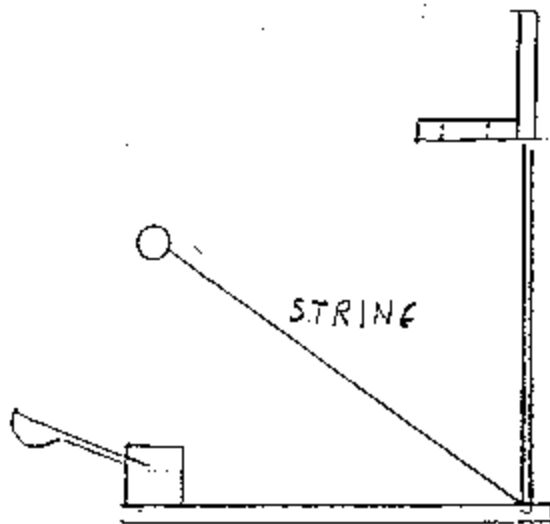

Family Time

By Barb Stephens

D L O Y A L D E U L A V R S L V R L
E Y D D T N U R T U R E T A S K S A
C S U P P O R T U N O I T A C A V U
I M E E T I N G Y T I R U C E S R G
S N D G N I G N A H C E G N I K I H
I J E F L E X I B L E C R A F T S A
O O T A G R O W I N G E K W J X E E
N B R T O X Y C V F F L D P O H S T
G S G R H L G A S L A E M C O D C A
N T N U P L R R W V N B Y R Z H W R
I E I S M O E I A X G R O C E R Y E
L R R T P V N N S V B A D O O F U P
C U A F L E E G R J V T D E F A S O
Y S H A E G A R B A G E L A D X Z O
C I S E H T O L C S N A F F I R M C
E E P I C N I C L Y L I M A F L C M
R L V R E S P E C T Z G N I V A S N
N E A T N E S S S E N I L N A E L C

Find the following words in the puzzle above. Words appear only horizontally or vertically.

AFFIRM

CLEANLINESS

DECISION

FOOD

HELP

LEISURE

MEETING

RESPECT

SECURITY

TASKS

CARING

CLOTHES

ENERGY

GARBAGE

HIKING

LOVE

NEATNESS

PICNIC

SHARING

TRUST

CELEBRATE

COOPERATE

FAMILY

GROCERY

JOBS

LOYAL

NURTURE

SAFE

SHOP

VACATATION

CHANGING

CRAFTS

FLEXIBLE

GROWING

LAUGH

MEALS

RECYCLING

SAVING

SUPPORT

VALUED

Exercise Warm-Up Fun

By Barb Stephens

Make sure the boys have plenty of room to move around. The leader should read it in a slow monotone at first while letting the boys go through the motions. Then try it in the sing-songy rhythm a little faster. Continue to repeat it, faster and faster, until either the boys or *the leader* collapse!

Hands on your hips, hands on your knees,
Put them behind you, if you please.
Touch your shoulders, touch your nose
Touch your ears, touch your toes.
Raise your hands high in the air,
At your sides, on your hair.
Raise your hands as before,
While you clap: one, two, three, four.
Your hands upon your head you place,
On your shoulders, on your face.
Then you raise them up on high,
And make your fingers quickly fly.
Then you put them in front of you,
And quietly clap: one, two; one two!

Your Body - A Wonderful Machine
Treat Your Body Right!
Circle T for True or F for False.

- T F 1. Smoking or chewing tobacco makes you *cool*.
- T F 2. Smoking can cause lung cancer and heart disease.
- T F 3. Athletes who smoke always play as long and as hard as athletes who don't smoke.
- T F 4. Smoking will not affect your eyes at all.
- T F 5. Smoking stains teeth and fingers.
- T F 6. Chewing tobacco is OK because it doesn't get into your body's organs.
- T F 7. Alcohol doesn't slow down the brain and body.
- T F 8. Alcohol can make a person see *double*.
- T F 9. Alcohol can make people do bad things they would *never* consider doing when sober.
- T F 10. Drunk drivers kill thousands of people each year.
- T F 11. All drugs, even prescription drugs, are dangerous.
- T F 12. It's OK to take someone else's medicine if you're sure you have the same illness.
- T F 13. Sniffing glue is OK to do once in a while.
- T F 14. Toxins from certain sniffing substances can affect the liver, kidneys and muscles.
- T F 15. Marijuana is OK in small amounts, but cocaine, heroin, and LSD are not.
- T F 16. Eating a cheeseburger, french fries and a soda for every lunch would be a balanced diet.
- T F 17. There are five food groups.
- T F 18. You should have 2 or more servings from each food group every day.
- T F 19. Your body needs vitamins, minerals, carbohydrates, fat and protein to operate smoothly.
- T F 20. Rushing meals or skipping meals can be harmful to your body.

Fun With Trees

Play On Names

Match each statement on the left to the appropriate tree on the right.

This tree comes in *twos*
This tree is *nearest the sea*
This tree is a *romantic evening for 2*
This tree *keeps you warm*
This tree was an *Egyptian plague*
The tree we offer when we *shake hands*
This tree is used in *kissing*
This tree is always *crying*
This tree is a *Colorado ski slope*

Date
Aspen
Locust
Pear
Tulip
Beech
Weeping
Palm
Fir

What Wood Would You Use?

Match the products on the left to the appropriate tree on the right.

baseball bats, tool handles
furniture, lumber, barrels
paper, soft lumber (derby cars)
gunstocks, cabinets
bowling alley lanes
lumber for outdoor decks

redwood
black walnut
pines
maples
ashes
oaks

Like A Rock

Use these words to fill in the blanks below.

volcanoes	mountains	geologist's hammer
magnifier	sedimentary rock	chisel
igneous rock	safety glasses	geysers
fossils	earthquake	metamorphic rock

Rock made by the cooling of magma; not layered; examples are granite and basalt.

Sediment that under great pressure becomes rock; it is layered; examples are sandstone, shale and conglomerate.

Baked rock or rock that has changed form; examples are marble and quartzite.

Used to pull rocks out of the hillside and for breaking them apart.

Used with a hammer to chip stone as well as for digging things loose.

These help protect eyes while digging and exploring.

This is a special type of glass that is used to make things appear larger so they can be examined more closely.

Holes in the ground through which streams of melted rock pour out of the earth; may form into a mountain peak.

Steam and boiling water that is blown into the air.

Rocks in one area (under great pressure from other rocks) that crack together and cause the phenomenon of "shaking" earth.

This land feature can be formed by volcanic action, erosion, or by uplift.

A trace of animal or plant life from millions of years ago that has hardened into rock.

The Tool Man!

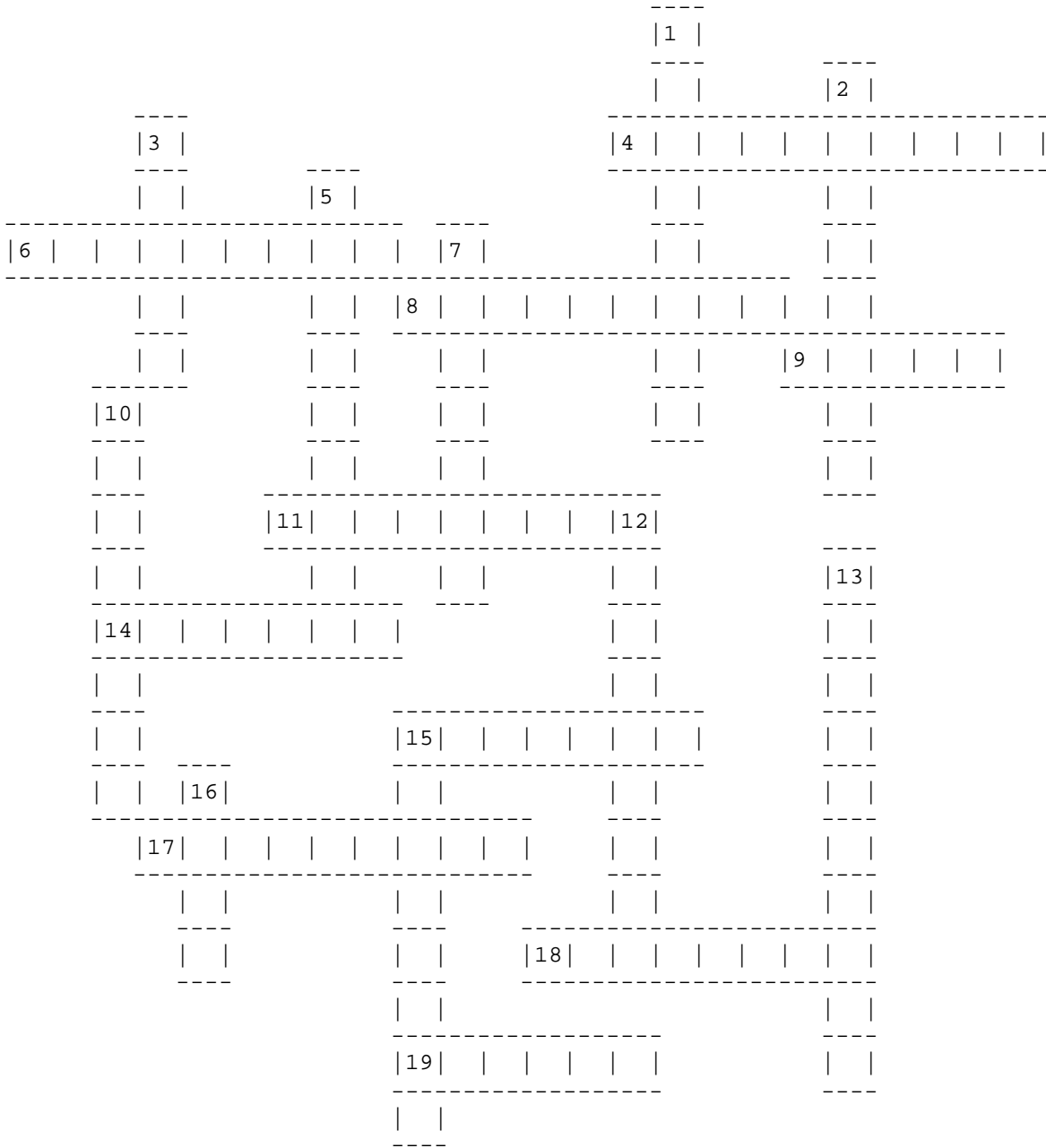

Fill in the words to the crossword puzzle using these clues.

ACROSS

4. Bright lights on the front of a car are ____ ____.
6. Cleaners that are _____ are often marked with a skull.
8. When it burns out, the ____ ____ must be replaced in a lamp.
9. The _____ bulb in a turn signal can burn out.
11. One light found on the back of a car is a _____.
14. If a bike chain becomes too loose, you must _____ it.
15. An area where tools are stored is a _____ area.
17. To keep the grass cut, use a _____.
18. Keep household _____ in a safe storage area.
19. The seat on a bike or horse is called a _____.

DOWN

1. Air inside a tire exerts _____.
2. Use the _____ to check the level of oil in your car.
3. The extra tire carried in a vehicle is called the _____.
5. When you put oil on your bike chain, you _____ it.
7. A two wheeled vehicle Scouts can ride is a _____.
10. A nail on the road may cause a _____.
12. You need a _____ to check tire pressure.
13. To add air to a tire, use a pump or air _____.
15. This "horse" is helpful when cutting boards.
16. On Saturday, many people _____ their car.

Being Handy Around The Home

Handy Ideas

Place a check in front of each of the following that is covered in the Handyman activity.

- | | |
|---|---|
| <input type="checkbox"/> Wash a car | <input type="checkbox"/> Clean up your toys |
| <input type="checkbox"/> Change a tire | <input type="checkbox"/> Adjust your bike's saddle |
| <input type="checkbox"/> Do the laundry | <input type="checkbox"/> Help mow the lawn |
| <input type="checkbox"/> Replace a lamp's lightbulb | <input type="checkbox"/> Store cleaning supplies safely |
| <input type="checkbox"/> Make a sawhorse | <input type="checkbox"/> Play with your sister or brother |
| <input type="checkbox"/> Make cookies | <input type="checkbox"/> Pick apples |
| <input type="checkbox"/> Plant a garden | <input type="checkbox"/> Inflate bike tires properly |
| <input type="checkbox"/> Tighten a bike chain | <input type="checkbox"/> Check tire pressure |
| <input type="checkbox"/> Rake grass clippings | <input type="checkbox"/> Adjust bike handlebars |
| <input type="checkbox"/> Check oil level | <input type="checkbox"/> Do your homework |
| <input type="checkbox"/> Cook a meal | <input type="checkbox"/> Organize tools safely & neatly |
| <input type="checkbox"/> Lubricate a bike | <input type="checkbox"/> Replace a rear car lightbulb |
| <input type="checkbox"/> Make your bed | <input type="checkbox"/> Empty wastebaskets |
| <input type="checkbox"/> Do the dishes | <input type="checkbox"/> Hang pictures |

Naturalist Activity Badge

Rare Bird Facts

Fill in the correct answer(s).

1. What is the fastest flying bird? _____
2. How high can birds fly? _____
3. What is the Nebraska State Bird? _____
4. What bird has become extinct in the last 75 years? _____
5. Why do all birds build nests? _____
6. Name two "major league" birds. _____
7. Which birds can fly backwards? _____
8. What bird is known for its famous deliveries? _____
9. What is the largest bird in North America? _____
10. What is the smallest bird in the world? _____
11. List three birds that **cannot** fly. _____
12. What color is a bluebird? _____

Answers - Rare Bird Facts

1. What is the fastest flying bird?
Swifts have been timed at 200 mph.
2. How high can birds fly?
A vulture has been seen flying at 25,000 feet, but most birds rarely fly above 3,000 feet.
3. What is the Nebraska State Bird?
Western Meadowlark
4. What bird has become extinct in the last 75 years?
Passenger Pigeon
5. Why do all birds build nests?
Birds build nests to "house" their eggs while they incubate
6. Name two "major league" birds.
Cardinal and Oriole
7. Which birds can fly backwards?
Hummingbirds or any bird using fluttering flight
8. What bird is known for its famous deliveries?
Stork
9. What is the largest bird in North America?
Trumpet Swan
10. What is the smallest bird in the world?
Bee Hummingbird of Cuba - 2.25" long
11. List three birds that cannot fly.
Kiwi, Penguin, Ostrich
12. What color is a bluebird?
It appears blue because of reflection and diffraction of light due to the structure of feathers

Outdoorsman Activity Badge

Knotty Knots

Knot Descriptions

Match each description on the left to the appropriate knot name on the right.

For tightening and loosening a rope easily and on guy lines.

Square Knot

For tying a rope to a post or ring; it's strong but easy to loosen.

Tautline Hitch

For tying a rope to a tree or post.

Clove Hitch

Used when you want a loop that will not slip or close up; used for rescue work.

Sheet Bend

For tying two ropes together and for tying bandages in first aid.

Bowline

For tying two ropes together, especially when one is thicker than the other.

Two Half Hitches

Forget-Me "Knots"

Match the knot picture to the knot name.

Square Knot

Tautline Hitch

Clove Hitch

Sheet Bend

Bowline

Two Half Hitches

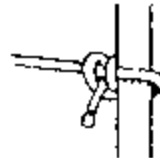
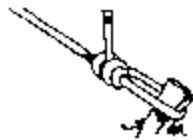
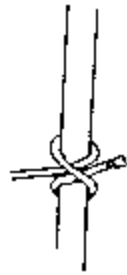

Zzz

Readyman Activity Badge

Be Prepared

Find and circle these items, then color them in:

A C E F G L M N O R Y - 9

B J S W 2 4 X T K D H P U Z 6 8 I Q V 7
I H D B V U T S 8 6 4 2 Q P K J 7 Z X W
H 7 U K B 8 C T J A P D L X 6 L W 4 I 2
2 X U Q I P T W B 6 D 4 8 J 7 H K 6 S P
B H K Q S U X 7 2 D I 6 J P 4 W 8 Z V T
I W 7 V J 9 9 9 B T U 9 X V W 9 W H K I
J V P U 9 K 7 9 I P 9 9 6 S 9 9 P T S W
D H T Q 9 4 S 9 T I K 9 W T J 9 K I T 8
2 U X J Z 9 9 9 4 S B 9 S W B 9 Z 4 I Q
S D 4 I W 6 B 9 Z J H 9 D T Z 9 D U D B
W W I X 7 X S 9 H 7 4 9 P K 7 9 I B P D
X T I H P I T 9 8 H Q 9 4 8 T 9 4 Q U I
7 B J S D J 2 9 V U V 9 T H I 9 X X T S
T J P D Q U W 9 K Z 9 9 9 P 9 9 9 T 6 Q
P S V H 8 W B D U K P 4 J B I T Q 6 W 2
I H D B V U T S 8 6 4 2 Q P K J 7 Z X W
B T S T P K Z F 6 T O Q V R H J 4 S 2 Z
B J S W 2 4 X T K D H P U Z 6 8 I Q V 7
P S V H 8 W B D U K P 4 J B I T Q 6 W 2
T D T W E X W M P 6 E B D R W H - V S D
2 X U Q I P T W B 6 D 4 8 J 7 H K 6 S P
B T 8 J G V T E H B N I B C J 4 Y H B U
H D 8 V U T S 8 Z 4 X Q P K J 7 Z 6 W I
K Q S U X 7 2 D I 6 J P 4 W 8 Z V T B H

Read the colored-in message to find out what to do in an emergency.

Scholar Activity Badge

Before the Meeting

1	2	3	4	5	6	7	8	9	10	11	12	13
14	15	16	17	18	19	20	21	22	23	24	25	26

1. If Jupiter is closer to the Sun than Mercury, write "V" in spaces 4, 20, 24, and 25. If not, write "S" in 4, 20, 24, and 25.
2. If it's OK to divide a number by zero, write "J" in spaces 13 and 22. If not, write "N" in spaces 13 and 22.
3. If you are the oldest person in this room, write the letter "X" in spaces 2, 7 and 23. If you are not, write "E" in these spaces.
4. If you like Christmas time better than being punished, indicate this with an "O" in 11 and 16. If not, leave these spaces empty.
5. Put your hands behind your back and by counting on your fingers, find the 7th letter of the alphabet. Write it in space 6.
6. If water freezes at 64 F, write an "P" in space 12. If not, write a "W" in that space.
7. If George Washington became president after Abe Lincoln, write nothing in space 8. If not, write a "T" in spaces 3, 8 and 15.
8. If 5 feet equals one mile, draw a house in space 1. Otherwise, write an "L" in space 1.
9. If you're a Webelos Scout, put the letter "D" in space 10, the letter "U" in space 19, and the letter "I" in space 21.
10. If you like this kind of "paper" game, write the second letter of the alphabet in space 18. If you don't, write a "B" in space 18.

Scholar Activity Badge

After the Meeting

1	2	3	4	5	6	7	8	9	10	11	12
13	14	15	16	17	18	19	20	21	22	23	24

1. If you ever saw a cow jump over the moon, write "Q" in spaces 1, 4, 15, 18. If not, write "R" in these spaces.
2. If "X" comes before "H" in the alphabet, write "Z" in space 3. If "X" comes after "H," write "F" in space 3.
3. If 13,467 is more than 10 dozen, write the letter "E" in spaces 2, 5, 9, 16, 19. If it is less than 10 dozen, write "K" in these spaces.
4. If you like candy better than mosquitoes, indicate this with an "S" in 6 and 12. If not, leave these spaces empty.
5. Close one eye and without counting on your fingers, write the 8th letter of the alphabet in space 7.
6. If Shakespeare wrote "Twinkle, Twinkle, Little Star," put a "C" in space 22. If he didn't, write a "Y" in that space.
7. If white is the same color as black, write nothing in space 8. If they are different colors, write an "M" in space 8.
8. If 10 quarts equals one cup, draw an elephant in space 10. Otherwise, write an "N" in space 10.
9. If summer is warmer than winter in the Northern hemisphere, put the letter "D" in space 21 and the letter "T" in space 11.
10. If you think this is silly, write the first letter of the alphabet in spaces 14 and 20. Otherwise, write an "A" in those spaces.

Fill in the words to the crossword puzzle using these clues.

ACROSS

2. B_____ developed the principle that explains how a plane can fly.
5. Air has W_____ in it, but the molecules are so small you don't always feel the dampness.
7. The force that keeps us from floating is called G_____.
8. The P_____ in the center of each eye adjusts in size depending on how much light is available.
9. P_____ discovered that pressure in a closed container of gas or liquid is equal in all directions.
11. An O_____ illusion is something you "see" that really isn't there.
13. The blanket of air around the earth is its A_____.
14. Your eyes are very much like the L_____ of a camera.
16. We learn all about these laws, principles, and phenomenon in the S_____ Activity.
17. I_____ is a phenomenon that says things in motion tend to stay in motion and things at rest tend to stay at rest.

DOWN

1. Some liquids when they get solid, form shapes called C_____ that are all the same shape.
2. Your B_____ enables you to stand steadily, and it's also a mechanical tool that lets you weigh things.
3. Mixing cool air into warm air causes a mist of F_____ to appear.
4. An educated scientific "guess" is a H_____.
6. An scientific task that tests a hypothesis is an E_____.
10. C_____ air used in machines like air pumps and jackhammers helps do work.
12. Air pressure at sea level is about 15 pounds per square inch, but in higher areas it decreases so the pressure is L_____.
15. The R_____ in the eye focuses an image of what you're looking at.

Showman Activity Badge

Hooray for Hollywood!

Z O D T E G T C A R E T S I S U M S P E K
B A R N E Y A L A T I B U S H W A C K E D
R K K S C O S T N E R J X V C O P E W A Y
H R D S Y O B H C A E B B I D R J M P N S
S I Q R N Z G O E J V I T E L N D S Y G T
B D N W A H S O N G O L D B E R G F I E R
N G I C T A W J I E L Y K Q I N R L L L F
E E K D B N O S B I G A T W F A V H H S E
H B L S G K J I W A E S A T N O H A C O P
R O U N L S S D W A I T M W E V L R I U S
T Y A P K D G K I L H I F C M A L K R T U
R S C R Y S T A L B V A L A D D I N E F T
R M S I D J I M L R T R A E O U B M I I R
K E R M I T A B I X P T S E P R S S H E Y
B N H R N P D J A C K S O N M L O L C L D
S R E X K N D G M E K X G O H N C N I D R
T E N O L L A T S H O P B L I C E R R Q I
E A S Y D J Q N C B I A I A Q X P H T J B
P P O W E R R A N G E R S E U T T K S B G
P E N N O S R P T Y M F G M I D B I G I I
U W G U A P M U G T S E R O F E O P V N B
M C I N T Y R E T W M R I H S R E G O R R

Find the capitalized words below in the puzzle above.

tom HANKS

danny GLOVER

sally FIELD

billy CRYSTAL

OAK RIDGE BOYS

reba MCINTYRE

ALADDIN

SISTER ACT

BUSHWACKED

ANGELS / OUTFIELD

jim HENSON

robin WILLIAMS

whoopie GOLDBERG

macauley CAULKIN

michael JACKSON

BEACH BOYS

george STRAIT

PECOS BILL

POCAHONTAS

FOREST GUMP

MUPPETS

BIG BIRD

mel GIBSON

goldie HAWN

kevin COSTNER

sly STALLONE

TLC

kenny ROGERS

HOME ALONE

RICHIE RICH

POWERRANGERS

BARNEY

KERMIT

Sportsman Activity Badge

The Penalty Box

Match the Officials' Signal Calls to the correct sport.

FOOTBALL

BASKETBALL

BASEBALL

SOCCER

HOCKEY

Pass Interference

Holding the Face Mask

Slashing

Fair Ball

Ball

Incomplete Pass

Penalty Kick

Holding

Safe

Tripping

Illegal Dribble

Keeing

Time-out

Offside

Hooking

Strike

Out

Clipping

Unsportsmanlike Conduct

Illegal Motion

Technical Foul

Time-in

Charging

Substitution

Corner Kick

Touchdown

Delay of Game

Foul Ball

Traveling

Foul

Traveler Activity Badge

Been There, Seen That!

I am famous for producing lots of maple syrup.

Mount Rushmore is one of my more popular tourist sites.

Dorothy and Toto are a couple famous "residents."

I'm home to the Grand Canyon.

The Rio Grande separates my southern border from Mexico.

I am home to the Liberty Bell.

I am home to Pikes Peak, one of the highest peaks in the Rockies.

My nickname is the Golden State.

I have one very large salty lake.

Three of my major lakes are Lake Tahoe, Lake Mead and Lake Mohave.

I am home to the Carlsbad Caverns National Park.

I'm famous for a horse derby and rolling green hills.

The Chesapeake Bay divides much of my land area.

I am home to over 10,000 lakes.

I am spread over many islands.

My name is from the Choctaw words "okla" & "homme."

I am the largest state in land size.

Most of Yellowstone National Park is in my north region.

My nickname is the Sunshine State.

I am surrounded by four Great Lakes.

I'm home to the Ozarks, Gateway Arch, and Silver Dollar City.

The widest river in the USA shares my name.